

ALUMWPA60 - 60" HEAVY-DUTY WORK PLATFORM

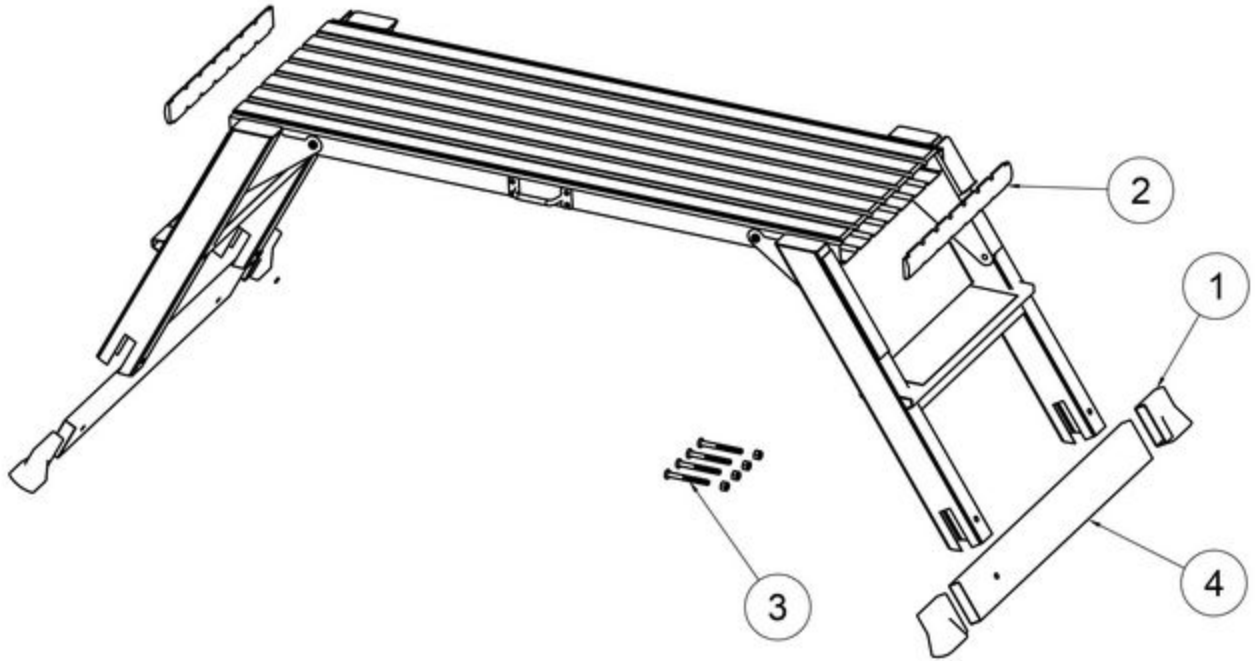

Item: ALUMWPA60

Description: 60" HEAVY-DUTY WORK PLATFORM

Notes: ALUMWPA60 warranty has been changed an M warranty to promote part replacement rather than warranting the entire Platform. See the Parts Manual for available replacement parts prior to contacting the supplier or attempting to warranty the entire Platform. Have Proof of Purchase and any pictures showing the issue with the Platform available when contacting the Supplier. Should the entire Platform need to be sent for warranty contact the Supplier at 740.363.1179 x222. Replacement for the end cap on the ALUMWPAHD is ALUMWPAHDEC

Figure No	Part Number	Description	No. Reqd	Warranty Code
1	BMALUMWPAHD1	RUBBER FT F/ALUMWPAHD	1	B
2	*BMALUMWPAHDE	END CAP (SOLD INDIVIDUALLY)	1	
3	*BMALUMWPAHD3	HARDWARE PACK FOR STABILIZER BAR	1	
4	BMALUMWPAHD2	STABILIZER F/ ALUMWPAHD & FEET	1	B