

Operating Instructions & Parts Manual



Body Repair Kits

Model
BRK4T
BRK10T

Capacity
4 Ton
10 Ton

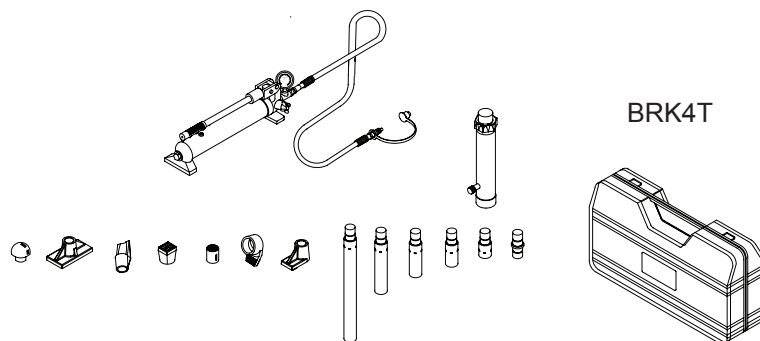

BRK4T

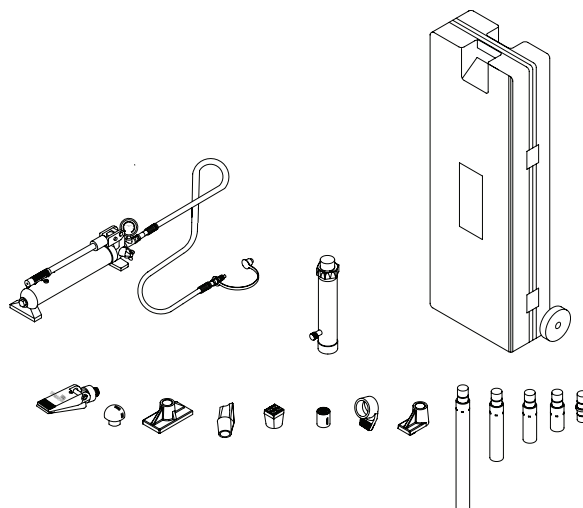

BRK10T



This is the safety alert symbol. It is used to alert you to potential personal injury hazards. Obey all safety messages that follow this symbol to avoid possible injury or death.

MATCO TOOLS

<http://www.matcotools.com>

Read this manual and follow all the Safety Rules and Operating Instructions before using this product.

SAFETY AND GENERAL INFORMATION

Save these instructions. For your safety, read, understand, and follow the information provided with and on this device before using. The owner and/or operator shall have an understanding of the device, its operating characteristics and safety operating instructions before operating the equipment. The owner and/or operator shall be aware that use and repair of this product may require special skills and knowledge. Instructions and safety information shall be read to and discussed with the operator in the operator's native language, making sure that the operator comprehends their contents, before use of this equipment is authorized. If any doubt exists as to the safe and proper use of this device, remove from service immediately.

Inspect before each use. Do not use if abnormal conditions such as cracked welds, damaged, loose or missing parts are noted. Any equipment that appears damaged in any way, is found to be worn, or operates abnormally shall be removed from service until repaired. If the equipment has been or is suspected to have been subjected to an abnormal load or shock, immediately discontinue use until inspected by a factory authorized repair facility (contact distributor or manufacturer for list of authorized repair facilities). It is recommended that an annual inspection be made by an authorized repair facility. Labels and Operator's Manuals are available from the manufacturer.

PRODUCT DESCRIPTION

Matco Tools Body Repair Kits are designed to be used for pushing, spreading, and pressing of vehicle body panels as well as various component parts and assemblies. A variety of attachments are included.

⚠ WARNING

When using extension tubes and/or offset attachments, reduce rated capacity by 50% for each tube or offset attachment connected. See Replacement Parts section on pages 8 & 9 for identification of "offset" attachments.

SPECIFICATIONS

Model	Pump Capacity	Ram Capacity	Ram		Number of Attachments
			Closed Height	Extended Height	
BRK4T	8,000 psi	4 Ton	10-3/4"	15-5/8"	14
BRK10T	10,000 psi	10 Ton	13-3/4"	19-3/4"	13

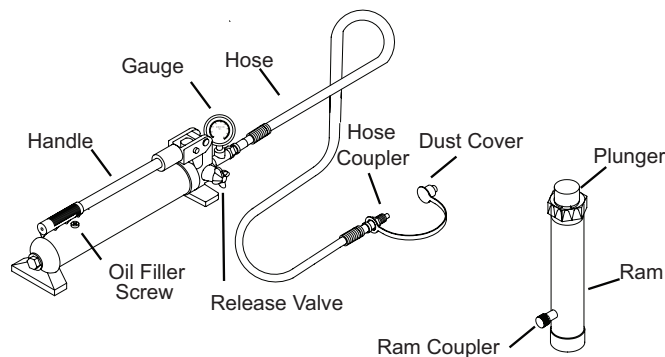

Figure 1 - BRK4T and BRK10T Components

⚠WARNING

- *Study, understand and follow all instructions before operating this device.*
- *Wear eye protective that meets ANSI Z87.1 and OSHA standards.*
- *Do not exceed the rated capacity.*
- *Use a pressure gauge that indicates pounds of force applied.*
- *When using extension tubes, position the shortest tube farthest from the cylinder.*
- *Do not subject the hose to extreme cold, heat, sharp surfaces, abrasion or impact.*
- *Do not allow the hose to kink, twist, curl or bend so tightly that it restricts fluid flow.*
- *Make sure setup is stable and secure before performing any work.*
- *No alterations or modifications shall be made to this product.*
- *Only components supplied with this kit shall be used with this kit.*
- *Failure to heed these markings may result in personal injury and/or property damage.*

⚠WARNING

ADDITIONAL SAFETY MESSAGES

- *Avoid short runs of straight line tubing. Straight line runs do not provide for expansion and contraction due to pressure and/or temperature changes.*
- *Long tubing runs should be supported by brackets or clips. Before operating the pump, all hose connections must be tightened with the proper tools. Do not overtighten. Connections should only be tightened securely and leak-free. Overtightening can cause premature thread failure or high pressure fittings to burst.*
- *Should a hydraulic hose rupture, burst or need to be disconnected, immediately shut off the pump and release all pressure. Never attempt to grasp a leaking pressurized hose with your hands. The force of escaping hydraulic fluid is under high pressure and can inflict injury.*
- *Do not pull, position or move setup by the hose. Doing so can damage the hose.*
- *Hoses also must not come in contact with corrosive materials such as battery acid, creosote-impregnated objects and wet paint. Never paint a coupler or hose.*
- *Inspect each ram and coupler before each use to prevent unsafe conditions from developing. Inspect the hose for wear.*
- *Do not use rams if they are damaged, altered or in poor condition.*
- *Do not use rams with bent or damaged coupler or damaged threads.*
- *Under certain conditions, the use of an extension with a hydraulic ram may not be advisable and could present a dangerous condition.*
- *Avoid pinch points or crush points that can be created by the load or parts of ram.*
- *To help prevent material fatigue if the ram is to be used in a continuous application, the load should not exceed 85% of the rated capacity.*
- *Ram must be on a stable base capable of supporting the load while pushing or lifting.*
- *Ensure ram is fully engaged into/onto adapters, extension accessories.*
- *Use shims, friction material or constraints to prevent slippage of the base or load.*
- *Do not off-center loads on a ram. The load can tip or the ram can "kick out" and cause personal injury.*
- *Never try to disassemble a hydraulic cylinder. Refer repairs to qualified, authorized personnel.*
- *Keep ram clean at all times.*
- *When not in use, keep ram fully retracted.*
- *Use an approved, high-grade pipe thread sealant to seal all hydraulic connections. Teflon tape can be used if only one layer of tape is used and it is applied carefully (two threads back) to prevent the tape from being introduced into hydraulic system. A piece of tape could travel through the system and obstruct the flow of fluid and adversely affect function.*

BEFORE USE

1. Before using this product, read the owner's manual completely and familiarize yourself thoroughly with the product, its components and recognize the hazards associated with its use.
2. Inspect before each use. Do not use if bent, broken, leaking or damaged components are noted.
3. Ensure all parts of your kit are included (ref. illustrations and parts list).
4. Remove dust caps and plugs from hose coupler and ram coupler.
5. Connect hose coupler to ram coupler, ensuring there are no fluid leaks.
6. Locate and open release valve. Close release valve clockwise and pump handle until ram is fully extended, then open release valve counter-clockwise until ram has fully retracted.
7. With ram fully retracted and release valve open, place pump in horizontal position. Open oil filler screw (located on reservoir body). This will release air trapped within the reservoir. Reinstall oil filler screw.

Bleeding Air from System

1. Bleed air from ram: Place pump at a higher elevation than the hose and ram as shown in Figure 2. With the objective being to force air up stream to the reservoir, close valve and extend ram as fast as possible. Open valve fully allowing oil and air to return to reservoir. Repeat procedure two or three times.
2. Bleed air from pump: With ram fully retracted, remove oil filler screw to let pressurized air escape, then reinstall oil filler screw.

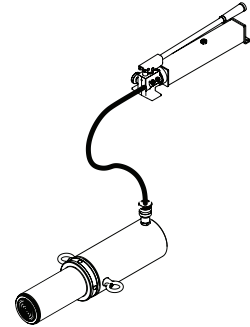

Figure 2 - Pump/ram air bleed

General Instruction

1. Pump may be used in horizontal or vertical position as illustrated (ref. Figure 3).
2. Attachments must be fully engaged before applying load.
3. Ensure load is centrally applied to attachment or ram saddle. Do not attempt off-center loading.
4. Always monitor the force applied to work piece by using a load cell and indicator, or monitor pressure developed in the ram by using an in-line pressure gauge, then calculate the applied force using the formula:
$$F = P \times A$$
where $F =$ lbs force, $P =$ pressure in psi, and $A =$ effective ram area in in^2 .
Ram Area of Model BRK4T is: 0.998 in^2
Ram Area of Model BRK10T is: 2.411 in^2
(ref. Load-Pressure Correlation chart on page 10)
5. If bowing or bending of ram or any attachment occurs during use, STOP IMMEDIATELY, release pressure and reconsider application. Application may require higher capacity ram kit.

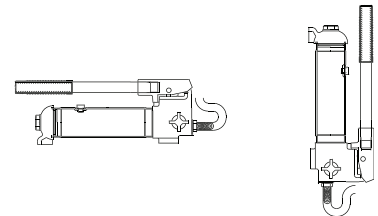

Figure 3 - Variable Position

⚠ WARNING

*When using extension tubes and/or offset attachments, reduce rated capacity by 50% for each tube or offset attachment connected. See **Replacement Parts** section on pages 8 & 9 for identification of "offset" attachments.*

Basic Setup

The capacity of the body repair kit can be significantly affected by the number of attachments used and the type of load applied. The approximate load capacity of each function setup is illustrated on page 5. When two or more extension tubes are used together, be sure to position the shorter tube furthest from the ram.

OPERATION

Applying Pressure to Work Piece:

1. Locate and close release valve by turning it clockwise until firmly closed. (Do not over tighten)
2. Operate by pumping handle. This will send fluid from the pump reservoir into the high pressure hose assembly and into the ram assembly.
3. Continue pumping until ram reaches desired position or overpressure situation is reached.

Releasing Pressure on Work Piece:

Slowly, carefully turn the release valve counter-clockwise until ram retracts to desired position. Never turn release valve more than 1/2 of a full turn. The ram return system is spring loaded and the release valve system is metered, allowing controlled retraction of the ram.

A. Pushing

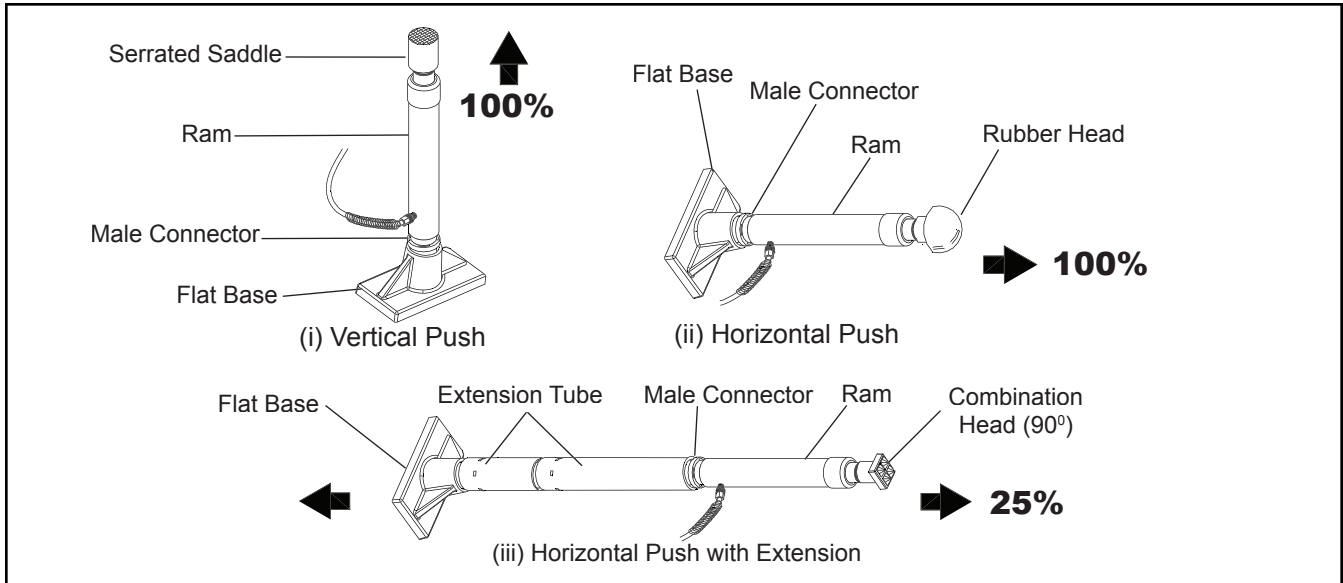

B. Spreading

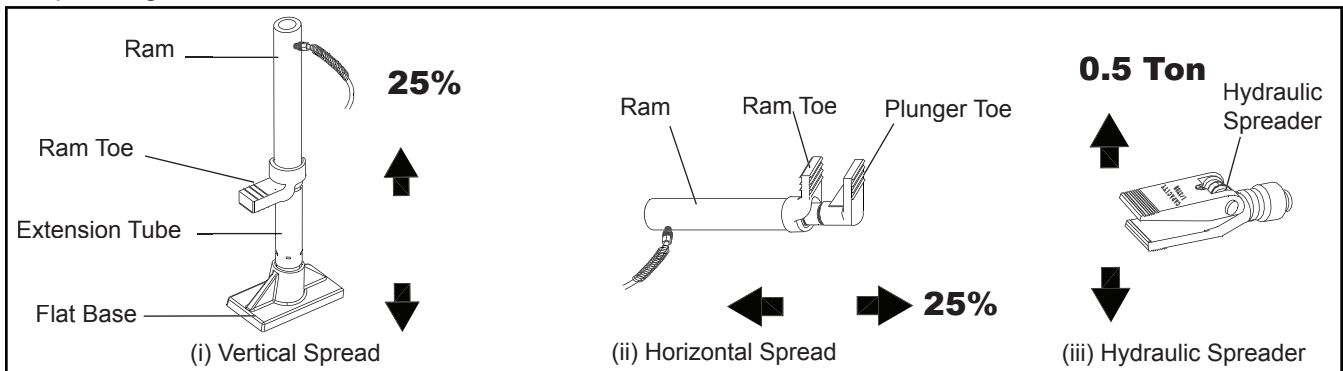

MAINTENANCE

NOTICE: Use only good quality hydraulic jack oil. Avoid mixing different types of fluid and NEVER use brake fluid, turbine oil, transmission fluid, motor oil or glycerin. Improper fluid can cause premature failure of the jack and the potential for sudden and immediate loss of load. Premium hydraulic jack oil is recommended.

Adding oil

1. With ram fully lowered, set pump unit in its normal, level position. Locate and remove oil filler screw.
2. Fill until oil is within 3/8" of the oil filler screw hole opening, re-install oil filler screw.

Changing oil

For best performance and increased system life, replace the complete fluid supply at least once per year.

1. With ram fully lowered, remove the oil filler screw from the pump reservoir as above.
2. Lay the pump on its side and drain the fluid into a suitable container.

NOTICE: Dispose of hydraulic fluid in accordance with local environmental regulations.

3. Set pump in its level upright position.
4. Fill with good quality jack oil to within 3/8" of the oil filler screw hole opening.
5. Perform **Bleeding/Air from System** procedure (page 4). Reinstall oil filler screw.

Lubrication

A coating of light lubricating oil to pivot points and hinges will help to prevent rust and assure that pump assemblies move freely.

Cleaning

Periodically check the pump piston and ram for signs of rust or corrosion. Clean as needed and wipe with an oily cloth.

NOTICE: Do not use sandpaper or abrasive material on ram or pump piston surfaces.

Storage

When not in use, store with the pump piston and ram fully retracted.

TROUBLESHOOTING GUIDE

The following information is intended as an aid in determining if problem exists. For repair service, contact Matco Tools service center in your area.

Symptom	Possible Causes	Corrective Action
Ram will not extend, or respond to pressurized fluid	<ul style="list-style-type: none"> • Overload condition • Release valve not closed 	<ul style="list-style-type: none"> • Remedy overload condition. • Ensure release valve closed
Ram responds to pressurized fluid, but system does not maintain pressure	<ul style="list-style-type: none"> • Overload condition • Release valve not closed • Hydraulic unit malfunction 	<ul style="list-style-type: none"> • Remedy overload condition • Ensure release valve closed • Contact Service Center
Ram will not return fluid to pump	<ul style="list-style-type: none"> • Malfunctioning coupler, damaged application • Reservoir overfilled 	<ul style="list-style-type: none"> • Secure load by other means. Open release valve, depressurize pump and hose, remove application and replace coupler • Secure load by other means, open release valve, depressurize pump and hose, remove application, then drain fluid to proper level
Ram will not fully extend (cylinder or spreader)	<ul style="list-style-type: none"> • Fluid level low 	<ul style="list-style-type: none"> • Secure load by other means, open release valve, depressurize pump and hose, remove application, then add fluid to proper level
Poor performance	<ul style="list-style-type: none"> • Fluid level low • Air trapped in system 	<ul style="list-style-type: none"> • Ensure proper fluid level • Perform Bleeding Air from System procedure (page 4)

REPLACEMENT PARTS

Not all components of the jack are replacement items, but are illustrated as a convenient reference of location and position in the assembly sequence. When ordering parts, give Model number, serial number and description below. Call or write for current pricing: Matco Tools 4403 Allen Road, Stow, OH 44224-1096, U.S.A. Tel:(866)BUY-TOOL Matco Tools Website: <http://www.matcotools.com>

Model BRK4T

Item	Part No.	Description	Qty
1	F040-90211-K01	Pump Assembly	1
2	F040-90009-K06	Ram Assembly	1
3	F040-22000-000	Hose Assembly (with coupler)	1
4	F040-00001-000	Blow Molded Case	1
5	F040-42000-000	Hydraulic Spreader (1000 lb. capacity)	1
6	F040-40002-000	Combination Head	1
7	F040-43000-000	Rubber Head	1
8	F040-40004-000	Ram Toe	1
9	F040-40005-000	Plunger Toe	1
10	F040-44000-000	Flat Base	1
11	F040-40003-000	Serrated Saddle	1
12	F040-40001-000	Wedge Head	1
13	F040-41600-000	Male connector	1
14	F040-41400-000	Extension Tube (3")	1
15	F040-41300-000	Extension Tube (6-1/8")	1
16	F040-41200-000	Extension Tube (8-1/2")	1
17	F040-41100-000	Extension Tube (16-1/2")	1
18	F040-41500-000	Extension Tube (19-1/2")	1
19	F040-22200-000	Release Valve Knob	1
20	F040-90009-K04	Ram Coupler Assy, Female	1
21	F040-20012-000	Dust Cover - Hose	1
22	F040-90009-K03	Pump Handle	1
23	F040-90107-K02	Oil Filler Screw	1
24	F100-80001-000	Gauge	1
-	F040S-85	Repair Kit	-
-	BRK4T-L0	Label	1
-	BRK4T-M0	Manual	1

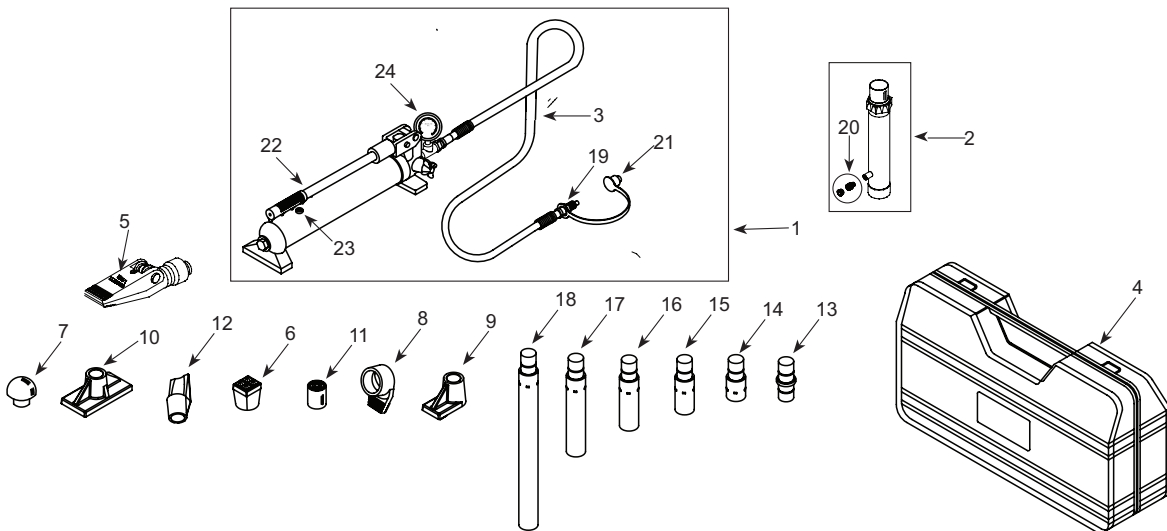

Figure 4 - Replacement Parts Illustration for Model BRK4T

Model BRK10T

Item	Part No.	Description	Qty
1	F100-90211-K01	Pump Assembly	1
2	F100-30000-000	Ram Assembly	1
3	F040-22000-000	Hose Assembly	1
4	F100-00004-000	Blow Molded Case	1
5	F040-42000-000	Hydraulic Spreader (1000 lb. capacity)	1
6	F100-40003-000	Combination Head (90°)	1
7	F100-42000-000	Rubber Head	1
8	F100-40005-000	Ram Toe (offset)	1
9	F100-40006-000	Plunger Toe (offset)	1
10	F100-40001-000	Flat Base	1
11	F100-40004-000	Serrated Saddle	1
12	F100-40002-000	Wedge Head (offset)	1
13	F100-41500-000	Male Connector	1
14	F100-41400-000	Extension Tube (4")	1
15	F100-41300-000	Extension Tube (10")	1
16	F100-41200-000	Extension Tube (18")	1
17	F100-41100-000	Extension Tube (27")	1
18	F040-90107-K02	Oil Filler Screw	1
19	F040-90009-K05	Hose Coupler, Male	1
20	F040-90009-K04	Ram Coupler Assy, Female	1
21	F040-20012-000	Dust Cover - Hose	1
22	F100-90009-K01	Pump Handle	1
23	F100-80001-000	Gauge	1
-	F1000S-85	Repair Kit	-
-	BRK10T-L0	Label (not shown)	1
-	BRK4T-M0	Manual	1

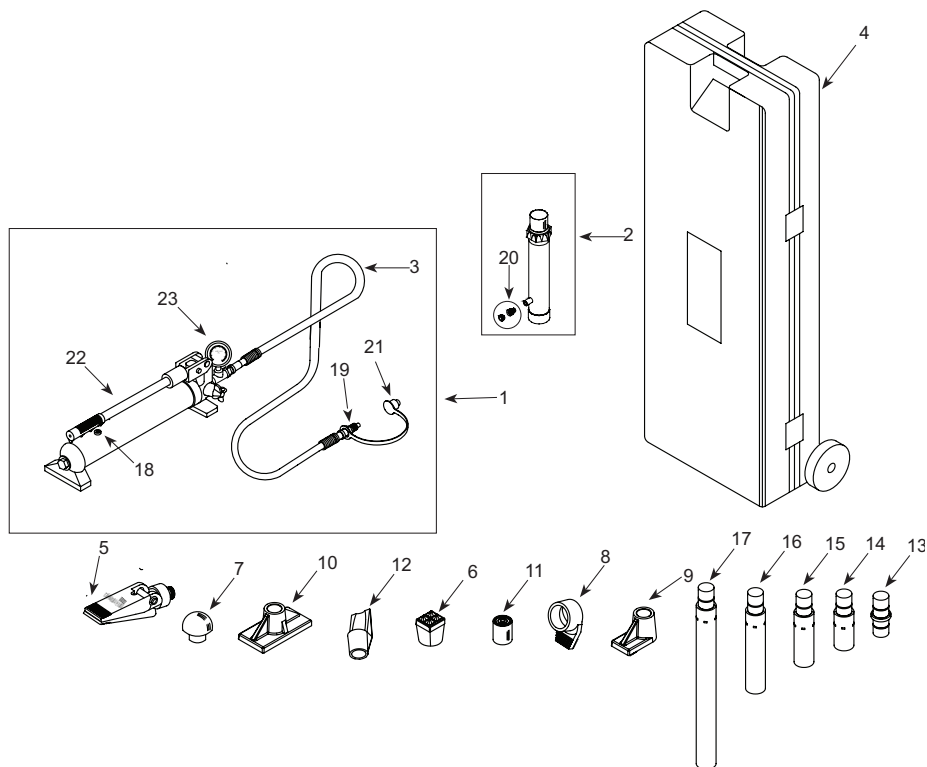

Figure 5 - Replacement Parts Illustration for Model BRK10T

LOAD - PRESSURE CORRELATION CHART

Models BRK4T & BRK10T

Always monitor the force applied to work piece by using a load cell and indicator or you may monitor pressure developed in the ram by using an in-line pressure gauge, then calculate the applied force using the formula:

$$F = P \times A$$

where F = Force/ Load (lbs)

P = Hydraulic Working Pressure (psi) and

A = Ram Effective Area (in²)*

Load (lbs)	Pressure (psi) of 4 Ton Ram, where A = 0.998 in ²	Pressure (psi) of 10 Ton Ram, where A = 2.411 in ²
1,000	1,002	415
2,000	2,004	830
3,000	3,006	1,244
4,000	4,008	1,659
5,000	5,010	2,074
6,000	6,012	2,489
7,000	7,014	2,903
8,000	8,016	3,318
9,000	\	3,733
10,000		4,148
11,000		4,562
12,000		4,977
13,000		5,392
14,000		5,807
15,000		6,221
16,000		6,636
17,000		7,051
18,000		7,466
19,000		7,881
20,000		8,295

*For Model BRK4T, $A = 0.998 \text{ in}^2$; For Model BRK10T, $A = 2.411 \text{ in}^2$

Example 1

Model BRK4T exerting 5,000 lbs of force will require what pressure?

$$\text{Pressure} = \text{Force} / \text{Ram Effective Area} = 5,000 \text{ lbs} / 0.998 \text{ in}^2 = 5,010 \text{ psi}$$

Example 2

Model BRK10T operating at 6,000 psi will generate what force?

$$\text{Force} = \text{Pressure} \times \text{Ram Effective Area} = 6,000 \text{ psi} \times 2.411 \text{ in}^2 = 14,466 \text{ lbs}$$



Matco Tools
4403, Allen Road, Stow, OH 44224-1096, U.S.A.
Tel: (866) BUY-TOOL
Matco Website: <http://www.matcotools.com>

ONE YEAR LIMITED WARRANTY

For a period of one (1) year from date of purchase, **Matco Tools** will repair or replace, at its option, without charge, any of its products, which fails due to a defect in material or workmanship under normal usage. This limited warranty is a consumer's exclusive remedy.

Performance of any obligation under this warranty may be obtained by returning the warranted product, freight prepaid, to **Matco Tools** Warranty Service Department, 4403 Allen Road, Stow, OH 44224-1096.

Except where such limitations and exclusions are specifically prohibited by applicable law, (1) THE CONSUMER'S SOLE AND EXCLUSIVE REMEDY SHALL BE THE REPAIR OR REPLACEMENT OF DEFECTIVE PRODUCTS AS DESCRIBED ABOVE. (2) **Matco Tools** SHALL NOT BE LIABLE FOR ANY CONSEQUENTIAL OR INCIDENTAL DAMAGE OR LOSS WHATSOEVER. (3) ANY IMPLIED WARRANTIES, INCLUDING WITHOUT LIMITATION THE IMPLIED WARRANTIES OF MERCHANTABILITY AND FITNESS FOR A PARTICULAR PURPOSE, SHALL BE LIMITED TO ONE YEAR, OTHERWISE THE REPAIR, REPLACEMENT OR REFUND AS PROVIDED UNDER THIS EXPRESS LIMITED WARRANTY IS THE EXCLUSIVE REMEDY OF THE CONSUMER, AND IS PROVIDED IN LIEU OF ALL OTHER WARRANTIES, EXPRESS OR IMPLIED. (4) ANY MODIFICATION, ALTERATION, ABUSE, UNAUTHORIZED SERVICE OR ORNAMENTAL DESIGN VOIDS THIS WARRANTY AND IS NOT COVERED BY THIS WARRANTY.

Some states do not allow limitations on how long an implied warranty lasts, so the above limitation may not apply to you. Some states do not allow the exclusion or limitation of incidental or consequential damages, so the above limitation or exclusion may not apply to you. This warranty gives you specific legal rights, and you may also have other rights, which vary from state to state.



Matco Tools
4403, Allen Road, Stow, OH 44224-1096, U.S.A.
Tel: (866) BUY-TOOL
Matco Website: <http://www.matcotools.com>