



## WARNING



Study, understand and follow all instructions provided with this product. Read these instructions carefully before installing, operating, servicing, or repairing this tool. Keep these instructions in a safe, accessible place.

### INTENDED USE OF THE TOOL

This heat gun was designed to be used for stripping paint, removing decals and pin striping, soften adhesives, drying, thawing, forming and welding plastics and more. Do not use this tool outside of the designed intent. Never modify the tools for any other purpose or use.

### BEFORE USE

Before use, **READ AND UNDERSTAND THE WARNINGS ON PAGE 1** and check the parts diagram and part number listing on page 4-5 to make sure all parts are included. If any parts are missing or damaged, please call your distributor.



## WARNING



### Caution: To help prevent personal injury

- Normal use of this product is likely to expose the user to dust and/or microscopic particles containing chemicals known to the State of California to cause cancer, birth defects or other reproductive harm. Always wear appropriate safety equipment and clothing when using this product. Study, understand and follow all instructions provided with this product. Failure to read and follow all warnings and operating instructions may result in damages and serious injury or death.
- Always wear ANSI approved goggles when using this product. (Users and bystanders).
- Never use this tool for any application other than for which it was designed.
- Only use accessories designed for this tool.
- Never alter or modify this tool in any way.
- Improper operation and/or maintenance of the tool, modification of the tool, or use of the tool with accessories not designed for it could result in serious injury or death.
- Always select the correct accessories of the correct size and design for the job that you are attempting to perform.
- Always work in a clean, safe, well-lit, organized and adequately equipped area.
- Never use the equipment as a hair dryer.
- Never block the air inlet or outlet.
- If the power cord is damaged, turn off the hot air gun immediately and don't use it again.
- Do not use the equipment in an explosive atmosphere (danger of explosion).
- Improper use can lead to fire.
- Do not aim the airflow directly at people or animals.
- When not in use, always store the equipment in a dry place, locked away and inaccessible to children.
- After using the equipment, place it down with the nozzle upward and before storing let it cool down completely.
- Never leave the gun unattended. Keep an eye on children.

### 1 YEAR LIMITED WARRANTY

The manufacturer warrants this product to the original user against defective material or workmanship for a period of 1 year from the date of purchase.

The manufacturer reserves the right to determine whether the part or parts failed because of defective material, workmanship or other causes. Failures caused by accident, alteration or misuse are not covered by this warranty.

The manufacturer, at its discretion, will repair or replace product covered under this warranty free of charge. Repairs or replacements of products covered under this warranty are warranted for the remainder of the original warranty period.

The manufacturer or its authorized service representatives must perform all warranty repairs. Any repair to the product by unauthorized service representatives voids this warranty. The rights under this warranty are limited to the original user and may not be transferred to subsequent owners.

The warranty is in lieu of all other warranties, expressed or implied, including warranties of merchantability and fitness for a particular purpose. Some states do not allow the exclusion or limitations of incidental or consequential damages, so the above limitations may not apply to you.

### PRODUCT INFORMATION



Made in China  
to Matco specifications

**Ergonomic design.** Temperature is adjusted with rear dial while air flow is set at the on/off switch.

**Everything you need.** Kit includes 5 accessories for scraping, paint and adhesive removal, wiring and more.

**Powerful performance.** Up to 1,500W of power for an adjustable 100-1,000°F temperature and 10 or 20 CFM of air flow.

#### Specification:

Voltage & Frequency: 120V~60Hz

Rate Power: 1,500W(MAX)

Adjustable Temperature: 100-1,000°F

Adjustable Air Flow: 10 or 20 CFM

### OPERATION

1. Adjust airflow level at the on/off switch for low (10 CFM) or high (20 CFM).
2. Adjust temperature with rear mounted dial. **Note that the 12 o'clock position is the setting (see arrow on gun body).** Thus, turn clockwise to increase temperature.

**DO NOT DISCARD – GIVE TO USER**



# ULTRA HEAT GUN

# HG300A

## ⚠ ADVERTENCIA ⚠

Estudie, entienda y siga todas las instrucciones que se proveen con este producto. Lea las instrucciones detenidamente antes de instalar, operar, dar servicio o reparar esta herramienta. Guarde estas instrucciones en un lugar seguro y accesible.

## USO PREVISTO DE LA HERRAMIENTA

This heat gun was designed to be used for stripping paint, removing decals and pin stripping, soften adhesives, drying, thawing, forming and welding plastics and more. No utilice esta herramienta fuera de la intención de su diseño. Nunca modifique las herramientas para ningún otro propósito o uso.

## DESEMPACADO

Antes de usar, **LEA Y COMPRENDA LAS ADVERTENCIAS EN LA PÁGINA 2** y verifique el diagrama de piezas y partes en la página 4-5 para asegurarse de que todas estén incluidas. En caso de que falten piezas o que estén dañadas, comuníquese con su distribuidor.

## ⚠ ADVERTENCIA ⚠

### Precaución: Para ayudar a evitar lesiones a las personas

- El uso normal de esta herramienta puede exponer al usuario al polvo o a partículas microscópicas que contienen sustancias químicas que se conocen en el estado de California por causar cáncer, defectos del nacimiento u otros daños reproductivos. Siempre use equipo y ropa de seguridad adecuados para trabajar con esta herramienta. Lea, comprenda y siga todas las instrucciones incluidas con esta herramienta. Omitir la lectura y el no seguir todas las advertencias e instrucciones de operación puede traer como consecuencia daños y lesiones graves o hasta la muerte.
- Siempre use guantes del tipo aprobado por la ANSI para trabajar con esta herramienta. (tanto usuarios como espectadores).
- Nunca utilice esta herramienta para cualquier otra cosa que no sean las aplicaciones para lo que fue diseñada.
- Sólo utilice los accesorios diseñados para esta herramienta.
- No modifique o altere esta herramienta de ninguna manera.
- El funcionamiento y/o mantenimiento inadecuado de la herramienta, la modificación, o la utilización de la herramienta con accesorios inadecuados podrían causar lesiones graves o la muerte.
- Siempre usar los correctos accesorios para el trabajo que Ud. está realizando.
- Trabaje siempre en un área limpia, segura, bien iluminada, organizada y equipada adecuadamente.
- **Never use the equipment as a hair dryer.**
- **Never block the air inlet or outlet.**
- **If the power cord is damaged, turn off the hot air gun immediately and don't use it again.**
- **Do not use the equipment in an explosive atmosphere (danger of explosion).**
- **Improper use can lead to fire.**
- **Do not aim the airflow directly at people or animals.**
- **When not in use, always store the equipment in a dry place, locked away and inaccessible to children.**
- **After using the equipment, place it down with the nozzle upward and before storing let it cool down completely.**
- **Never leave the gun unattended. Keep an eye on children.**

## GARANTÍA LIMITADA DE UN AÑO

El fabricante garantiza este producto al usuario original contra defectos de materiales o de mano de obra durante un periodo de un año a partir de la fecha de compra.

El fabricante se reserva el derecho a determinar si una pieza o piezas fallaron debido a material defectuoso, mano de obra, o por otras causas. Esta garantía no cubre fallas causadas por accidentes, alteraciones o uso indebido.

El fabricante, a su entera discreción, reparará o reemplazará los productos cubiertos por esta garantía sin costo alguno. Las reparaciones o reemplazos de productos cubiertos por esta garantía quedan garantizados durante el resto del periodo original de garantía.

El fabricante o sus representantes autorizados de servicio deben llevar a cabo todas las reparaciones de garantía. Toda reparación hecha al producto por representantes de servicio no autorizados invalida la presente garantía. Los derechos que ampara esta garantía están limitados al usuario original y no se pueden transferir a dueños posteriores.

Esta garantía reemplaza a todas las demás garantías expresas o implícitas, incluyendo garantías de comercialización e idoneidad para un propósito particular. Algunos estados no permiten la exclusión o limitaciones de daños incidentales o imprevistos, de manera que las limitaciones mencionadas anteriormente pueden no ser aplicables en su caso.

## INFORMACIÓN DEL PRODUCTO



Hecho en China  
Para Matco especificaciones

**Ergonomic design.** Temperature is adjusted with rear dial while air flow is set at the on/off switch.

**Everything you need.** Kit includes 5 accessories for scraping, paint and adhesive removal, wiring and more.

**Powerful performance.** Up to 1,500W of power for an adjustable 100-1,000°F temperature and 10 or 20 CFM of air flow.

### Specification:

Voltage & Frequency: 120V~60Hz

Rate Power: 1,500W(MAX)

Adjustable Temperature: 100-1,000°F

Adjustable Air Flow: 10 or 20 CFM

## OPERATION

1. Adjust airflow level at the on/off switch for low (10 CFM) or high (20 CFM).
2. Adjust temperature with rear mounted dial. **Note that the 12 o'clock position is the setting (see arrow on gun body).** Thus, turn clockwise to increase temperature.

**NO LO DESCARTE O DESECHE, ENTREGUESELO AL USUARIO**

**⚠ AVERTISSEMENT ⚠**

Étudier, comprendre et suivre toutes les instructions fournies avec ce produit. Lire ces instructions attentivement avant d'installer, d'utiliser, d'entretenir et de réparer cet outil. Conserver ces instructions dans un endroit sécuritaire et accessible.

**UTILISATION PRÉVUE DE L'OUTIL**

This heat gun was designed to be used for stripping paint, removing decals and pin striping, soften adhesives, drying, thawing, forming and welding plastics and more. N'utilisez pas cet outil en dehors de l'intention prévue. Ne modifiez jamais l'outil à d'autres fins ou utilisation.

**DÉBALLAGE**

Before use, **READ AND UNDERSTAND THE WARNINGS ON PAGE 3** and check the parts diagram and part number listing on page 4-5 to make sure all parts are included. Si une pièce est manquante ou abîmée, veuillez appeler immédiatement votre distributeur.

**⚠ AVERTISSEMENT ⚠**

**Mise en garde: Pour aider à prévenir les blessures**

- L'utilisation normale de ce produit pourrait exposer l'utilisateur à de la poussière et/ou des particules microscopiques contenant des produits chimiques que l'État de la Californie a reconnu comme étant une cause de cancer, de déficience congénitale et d'autres effets nocifs sur le système reproductif. Toujours porter un équipement et des vêtements sécuritaires appropriés en utilisant ce produit. Étudier, comprendre et suivre toutes les instructions fournies avec ce produit. Echec de lire et suivre des avertissements et le mode d'emploi devrait causer des endommages et des blessures sévères ou la mort.
- Toujours porter des lunettes à coques approuvées par l'ANSI lorsque vous utilisez ce produit. (Utilisateurs et Spectateurs).
- Ne jamais utiliser cet outil pour aucune application qui n'est pas conçue.
- Seulement utiliser les accessoires conçus pour cet outil.
- Ne jamais modifier cet outil.
- Le fonctionnement et/ou l'entretien incorrect de cet outil, la modification de cet outil, ou l'utilisation de cet outil avec les accessoires non conçus pour lui devrait causer des blessures graves ou la mort.
- Toujours utiliser les accessoires adéquats pour le travail que vous effectuez.
- Toujours travailler dans un environnement propre, sécuritaire, bien éclairé, organisé et suffisamment équipé.
- **Never use the equipment as a hair dryer.**
- **Never block the air inlet or outlet.**
- **If the power cord is damaged, turn off the hot air gun immediately and don't use it again.**
- **Do not use the equipment in an explosive atmosphere (danger of explosion).**
- **Improper use can lead to fire.**
- **Do not aim the airflow directly at people or animals.**
- **When not in use, always store the equipment in a dry place, locked away and inaccessible to children.**
- **After using the equipment, place it down with the nozzle upward and before storing let it cool down completely.**
- **Never leave the gun unattended. Keep an eye on children.**

**1 ANNÉE DE GARANTIE LIMITÉE**

Le fabricant garantit à l'acheteur initial que ce produit est exempt de tout vice de matériau et de fabrication pendant une période de une année suivant la date de l'achat.

Le fabricant se réserve le droit de déterminer si la pièce ou les pièces défectueuses sont imputables à un matériau défectueux, à un défaut de fabrication ou à d'autres causes. Les défaillances causées par un accident, une modification ou une utilisation incorrecte ne sont pas couvertes par la présente garantie.

Le fabricant, à sa seule discrétion, réparera ou remplacera sans frais les produits couverts par cette garantie. Les réparations ou les remplacements de produits couverts par cette garantie sont garantis pour le reste de la période de garantie initiale.

Le fabricant ou ses représentants de service autorisés doivent exécuter les réparations sous garantie. Toute réparation du produit effectuée par un représentant de service non-autorisé annulera cette garantie. Les droits couverts par cette garantie sont limités à l'acheteur initial et ne peuvent être transférés aux propriétaires subséquents.

Cette garantie remplace toutes autres garanties, expresses ou implicites, incluant les garanties de valeur marchande ou d'adaptation à un usage particulier. Certains États ou provinces ne permettent pas d'exclure ou de limiter les dommages consécutifs ou indirects, donc les limitations ci-dessus pourraient ne pas s'appliquer.

**INFORMATIONS PRODUIT**



FABRIQUÉ EN CHINE  
les spécifications de Matco

**Ergonomic design.** Temperature is adjusted with rear dial while air flow is set at the on/off switch.

**Everything you need.** Kit includes 5 accessories for scraping, paint and adhesive removal, wiring and more.

**Powerful performance.** Up to 1,500W of power for an adjustable 100-1,000°F temperature and 10 or 20 CFM of air flow.

**Specification:**

Voltage & Frequency: 120V~60Hz

Rate Power: 1,500W(MAX)

Adjustable Temperature: 100-1,000°F

Adjustable Air Flow: 10 or 20 CFM

**OPERATION**

1. Adjust airflow level at the on/off switch for low (10 CFM) or high (20 CFM).
2. Adjust temperature with rear mounted dial. **Note that the 12 o'clock position is the setting (see arrow on gun body).** Thus, turn clockwise to increase temperature.

**NE PAS JETER-DONNER À L'UTILISATEUR**

**PARTS BREAKDOWN**



**Parts List**

Index #	Part #	Description	Q'ty
1	HG300A-01	Ultra Heat Gun	1
2	HG300A-02	Fishtail Nozzle	1
3	HG300A-03	Spoon Reflector	1
4	HG300A-04	Concentrated Scoop	1
5	HG300A-05	Concentrated Nozzle	1
6	HG300A-06	Triangular Scraper	1
7	HG300A-07	Wooden Handle	1

**PARTS BREAKDOWN FOR THE ULTRA HEAT GUN**

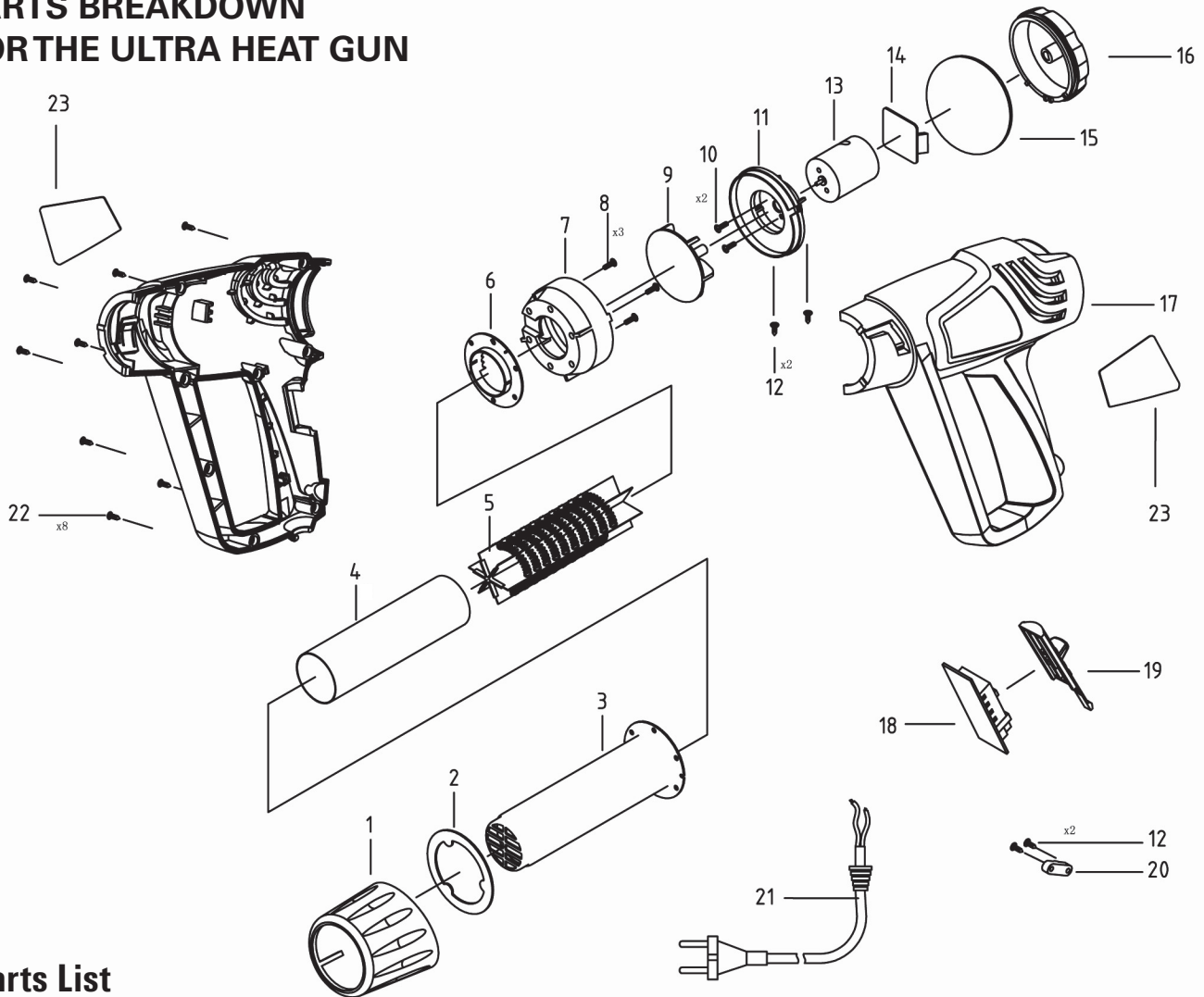

**Parts List**

Index #	Part #	Description	Q'ty
1	HG300A-08	Plastic Tube	1
2	HG300A-09	Steel Ring	1
3	HG300A-10	Steel Tube	1
4	HG300A-11	Mica Paper	1
5	HG300A-12	Heating Element	1
6	HG300A-13	Ring	1
7	HG300A-14	Plastic Fan	1
8	HG300A-15	M3*9 Screw	3
9	HG300A-16	Fan Blade	1
10	HG300A-17	M2.5*5 Screw	2
11	HG300A-18	Motor Stand	1
12	HG300A-19	M3x12 Screw	4

Index #	Part #	Description	Q'ty
13	HG300A-20	D.C.Motor	1
14	HG300A-21	Motor Board	1
15	HG300A-22	Temperature Dial	1
16	HG300A-23	Tail Hood	1
17	HG300A-24	Housing	1set
18	HG300A-25	Switch	1
19	HG300A-26	Switch Plate	1
20	HG300A-27	Cord Grip	1
21	HG300A-28	Power Cord	1
22	HG300A-29	M3x14 Screw	8
23	HG300A-30	Lable	1set