

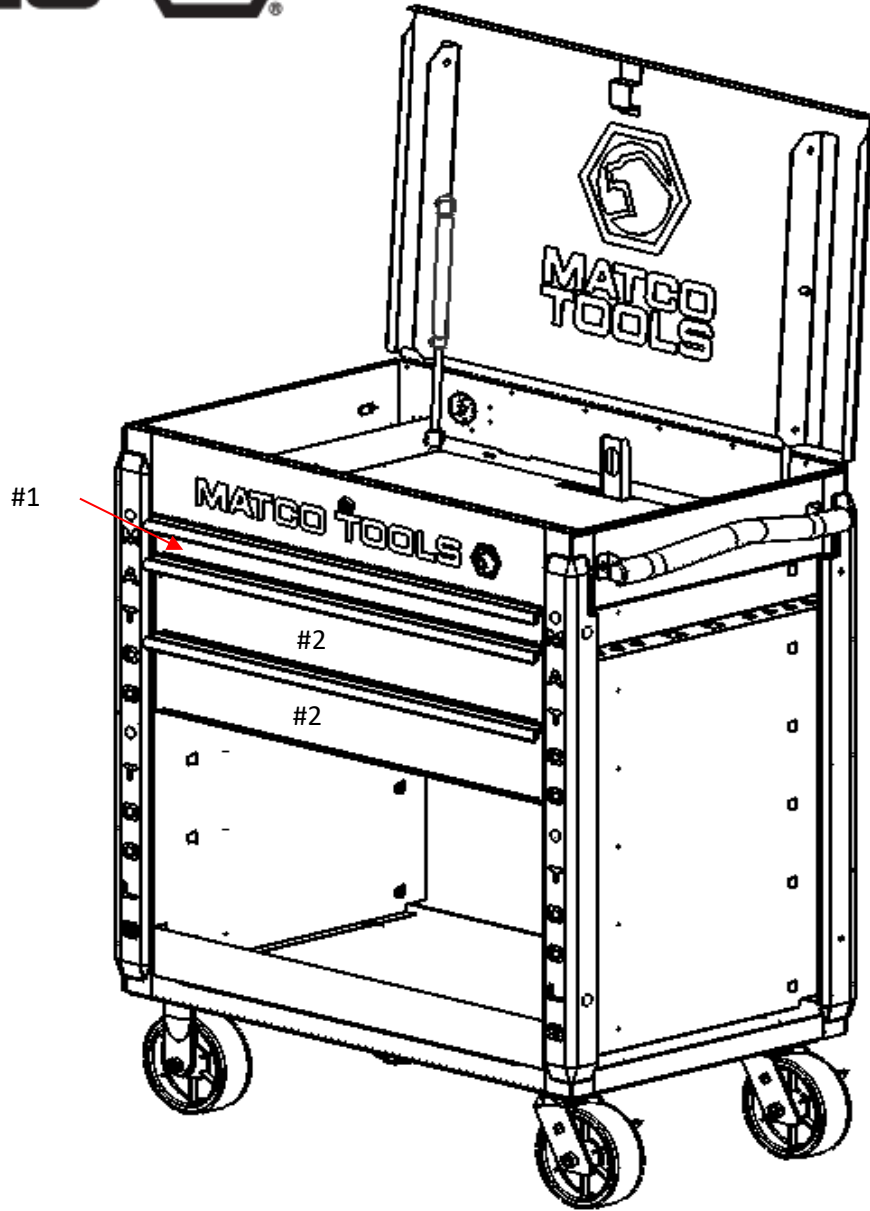

# JSC450

JAMESTOWN SERVICE CART -450



SPECIFICATIONS							
PART NUMBER	DESCRIPTION	QTY	HEIGHT	WIDTH	DEPTH	SQ IN	CU IN
JSC480-053	#1 DRAWER	1	1.656	28.500	19.533	557	922
JSC480-055	#2 DRAWER	2	4.063	28.500	19.533	1,113	4,524
LID AREA		1	4.956	33.466	20.688	692	3,431
BOTTOM STORAGE		-	9.125	23.500	19.594	-	-
<b>TOTAL / OVERALL</b>		<b>4</b>	<b>42.319</b>	<b>34.537</b>	<b>21.741</b>	<b>2,362</b>	<b>8,877</b>

\*ALL DIMENSIONS IN INCHES



# JSC450

JAMESTOWN SERVICE CART -450

REPLACEMENT PARTS			
ITEM	PART #	DESCRIPTION	QTY/BOX
1	CSTR-028	SWIVEL CASTER	2
2	CSTR-048	RIGID CASTER	2
3	BOLT-012	5/16-18 X 5/8 HWH CASTER BOLT	16
4	JSC480-044	LOCKBAR	1
5	SPRG-011	LOCKBAR SPRING	1
6	DECAL-L/U	LOCK/UNLOCK DECAL	1
7	LTCH-011	LATCH	1
8	LOCK-017	1 LOCK W/ 2 KEYS	1
	LOCK-017B	1 LOCK W/ 2 KEYS (BLACK)	
9	NUTS-MP7	LOCK NUT	1
10	CAMS-400	LOCK CAM	1
11	JSC480-094	LID	
12	DECAL-12W	MATCO TOOLS DECAL (WHITE)	1
	DECAL-12B	MATCO TOOLS DECAL (BLACK)	
13	NUTS-025	NUT	4
14	STUD-010	BALL STUD	4
15	SHOK-015	25# GAS SHOCK	2
16	RIVT-020	3/16" X 1/2" RIVET	8
17	GARD-016	EDGE GUARD	1
18	JSC450-060	LOCKBAR COVER	1
19	RIVET-016C	CHROME RIVET	4
20	JSC450-085	BOTTOM FRONT	1
21	SCRW-027	8-32X1/4"PPH SCREW (DWR TO SLIDE, 2/DWR)	6
22	SCRW-047	#8 X 1/4" TORX PH SCREW (CASE TO SLIDE, 2/DWR)	6
23	BUMP-JSC500L	LEFT BUMPER	2
24	BUMP-JSC500R	RIGHT BUMPER	2
25	BUMP-CLIP	BUMPER FASTENER	16
26	SHNDL-400	SIDE HANDLE	1
27	HDWE-CORESH	SIDE HANDLE HARDWARE	1
28	LABL-028	CAUTION LABEL	1
29	L37	LID LINER	1
30	L38	DRAWER LINER	3
31	STRP-C29531	CHROME STRIP HANDLE	3
	STRP-BB29531	BLACK STRIP HANDLE	
32	CHRN-619M	DRAWER SLIDES	6
33	JSC480-053	#1 DRAWER	1

34	JSC480-055	#2 DRAWER	2
35	GROM-250	POWER GROMMET	1
36			

REVISION	DESCRIPTION	DATE	BY	EC #
A	CREATION	1/30/2019	SRG	

# JSC450

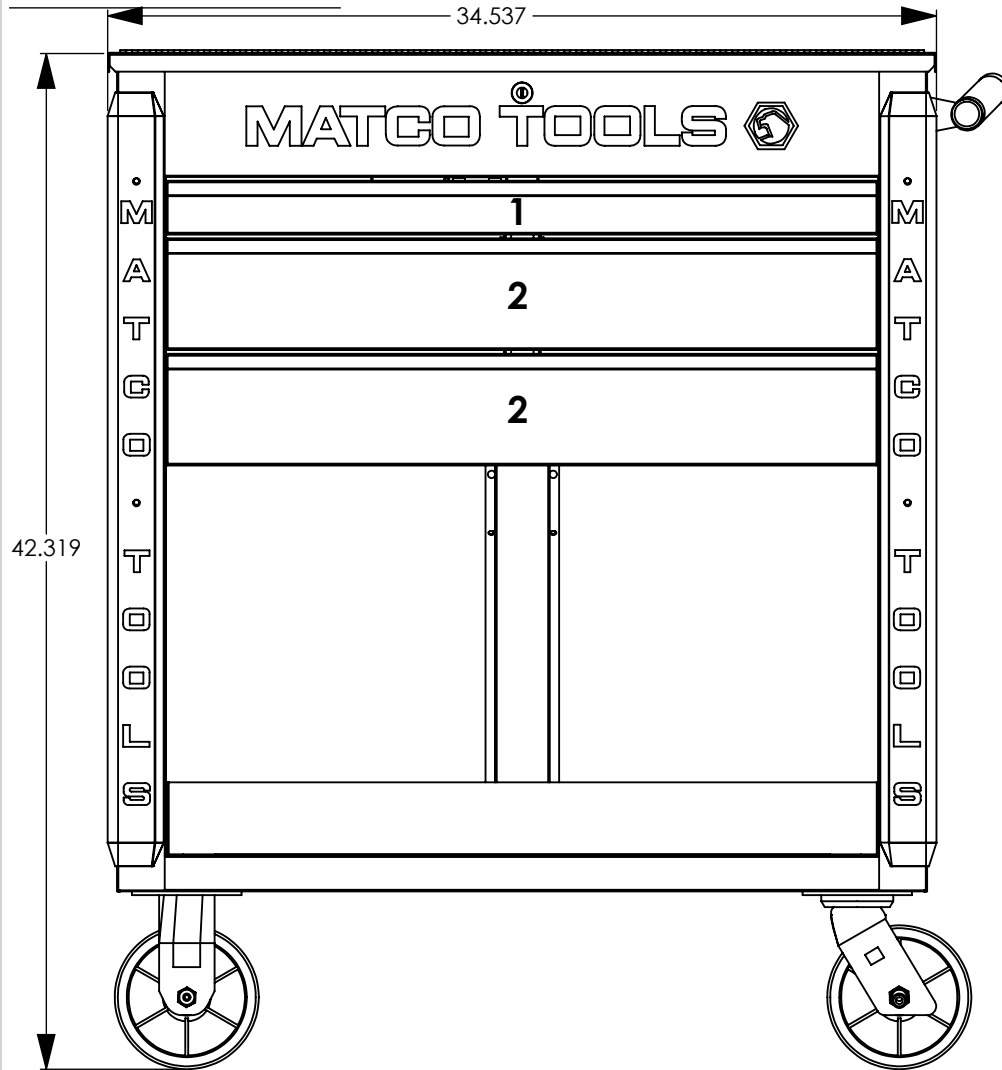

DRAWER PART NO.	DWR NO.	QTY.	H	W	D	SQ. IN.	CU. IN.
JSC480-053	1	1	1.656	28.500	19.533	557	922
JSC480-055	2	2	4.063	28.500	19.533	1113	4523
LID AREA		1	4.956	33.466	20.580	689	3413
<b>LOCKABLE STORAGE TOTAL</b>						2359	8858
BOTTOM BULK STORAGE (NON LOCKING)		1	14.492	29.662	20.688	614	8893
<b>TOTAL STORAGE</b>						2972	17751
OVERALL DIMENSIONS			42.319	34.537	21.741		

*\*LID AREA INCLUDES 10 TOOL STORAGE HOLES PER SIDE (20 TOTAL)*

KEY NO.	SERIAL NO. RANGE (After):
 <p><b>MATCO TOOLS</b> JAMESTOWN TOOLBOX PLANT 160 CHAUTAUQUA AVENUE LAKEWOOD, NY 14750</p>	
DWG. NO. JSC450-SPEC	REV. A LEVEL 4/24/14